

# VOGUEknitting

## CASCADE YARNS



- Length 21 (22, 23)"/53 (56, 58)cm
- Upper arm 16 (17½, 19)"/40.5 (44.5, 48.5)cm

### MATERIALS

- 7 (8, 10) 3½oz/100g balls (each approx 108yds/99m) of Cascade Yarns *Baby Alpaca Chunky* (alpaca) in #565 off white
- One pair size 10 (6mm) needles OR SIZE TO OBTAIN GAUGE

### GAUGE

15 sts and 18 rows to 4"/10cm over St st using size 10 (6mm) needles.

TAKE TIME TO CHECK GAUGE.

### SEED STITCH

**Row 1 (RS)** \*K1, p1; rep from \* to end.

**Row 2** Knit the purl sts and purl the knit sts.

Rep row 2 for seed st.

### BACK

Cast on 68 (76, 82) sts. Work in seed st for 5"/12.5cm. Work in St st until piece measures 16 (17, 18)"/40.5 (43, 46)cm from beg. Work in seed st until piece measures 21 (22, 23)"/53 (56, 58)cm from beg. Bind off.

### RIGHT FRONT

Cast on 34 (38, 41) sts. Work in seed st for 5"/12.5cm, end with a WS row.

### Establish seed st band

**Next row (RS)** Work 5 sts in seed st, k to end of row.

Work even keeping 5 sts at front edge in seed st and rem sts in St st as established until piece measures 16 (17, 18)"/40.5 (43, 46) cm from beg. Work all sts in seed st until piece measures 21 (22, 23)"/53 (56, 58) cm from beg. Bind off.

front edge in seed st and rem sts in St st as established until piece measures 16 (17, 18)"/40.5 (43, 46) cm from beg. Work all sts in seed st until piece measures 21 (22, 23)"/53 (56, 58) cm from beg. Bind off.

### LEFT FRONT

Cast on 34 (38, 41) sts. Work in seed st for 5"/12.5cm, end with a WS row.

### Establish seed st band

**Next row (RS)** K to last 5 sts, work 5 sts in seed st. Complete as for right front, reversing 5-st seed st band as established.

### SLEEVES

Cast on 60 (66, 72) sts. Work in seed st for 4"/10cm. Work in St st until piece measures 16 (17, 18)"/40.5 (43, 46)cm from beg. Bind off.

### FINISHING

Mark center 8"/20.5cm of bound-off edge of back for back neck. With WS tog, sew fronts and back tog for 5 (6, 7)"/12.5 (15.5, 17.5)cm along bound-off edges for shoulders. Mark side edges 8 (8¾, 9)"/20.5 (22, 23)cm down from shoulder seams for armholes. Sew bound-off edge of sleeve between markers. Sew side and sleeve seams. Turn up cuffs and tack in place at seam edge.

### Lapels

Fold back 4"/10cm on each front neck corner for lapels, sew in place. ❖

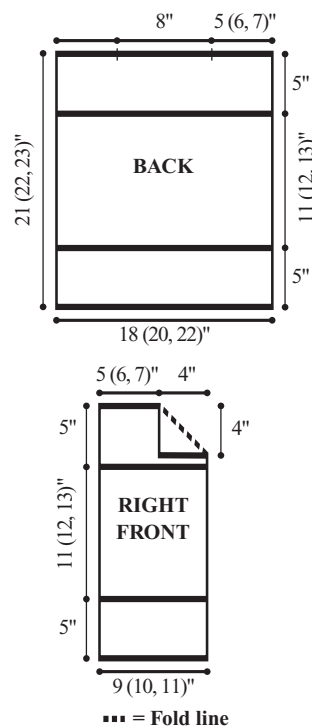

## CROPPED JACKET

As seen in *Vogue Knitting* Winter 2007/08, page 60. Sized for Small, Medium and Large. Shown in size Medium.



### KNITTED MEASUREMENTS

- Bust (closed) 36 (40, 44)"/91 (101.5, 111.5)cm

