

19 MODULAR STRIPE DRESS

Shown in *VK* Fall 2008 on page 94. Instruction on pages 134 & 135.

Corrections are underlined.

REV ST ST STRIPE PAT

Rows 1 and 3 (WS) With A, knit.

Rows 2 and 4 With A, purl.

Row 5 With B, knit.

Row 6 With B, purl.

Row 7 With A, knit.

Row 8 With A, purl. Rep these 8 rows for rev St st stripe pat.

SKIRT WEDGE

(make 2 identical pieces)

With larger needles and A (B, A, B), cast on 108 sts. Work rows 5–8 for 0 (1, 0, 1) time. Then, work rows 1–8 of rev St st stripe pat 6 (6, 7, 7) times for a total of 48 (52, 56, 60) rows. The remainder of the skirt wedge is worked in the continuing stripe pat with short row shaping for lower edge flare.

Short row 1 (WS) K96, w & t.

Short row 2 Purl.

Short row 3 K88, w & t.

Short row 4 and all even short rows Purl.

Short row 5 K80, w & t.

Short row 7, 9, 11, 13, 15, 17, 19 and 21 K72, then k64, 56, 48, 40, 32, 24 then 16 on each subsequent WS short row OR 8 sts less each WS short row.

Short row 23 K8, w & t.

Short row 25 K4, w & t. Beg next row with row 5 of stripe pat and cont as foll:

Short row 27 K16, w & t.

Short row 29 K24, w & t.

Short rows 31, 33, 35, 37, 39, 41, 43, 45 and 47 K32 then k40, 48, 56, 64, 72, 80, 88 then 96 on each subsequent WS short row OR 8 sts more each WS short row.

Short row 48 Purl.

Rows 49 and 50 Work even on all sts. Then, cont in stripe pat until there are same number

of stripe rows as the first half of the wedge OR 46 (50, 54, 58) rows more. Bind off.

RIGHT FRONT/LEFT BACK BODICE

(make 2 identical pieces)

Note These pieces are worked down from the top edge to the waist edge of the bodice. With larger needles and A, cast on 11 (13,

15, 17) sts. Beg with row 3 of 8-row stripe pat, work as foll:

Row 1 (WS) Knit.

Row 2 Purl.

Row 3 (WS) Cast on 7 sts, k to last 4 sts, k2tog, k2—17 (19, 21, 23) sts. Cont to cast on 7 sts at beg of every WS row 3 times

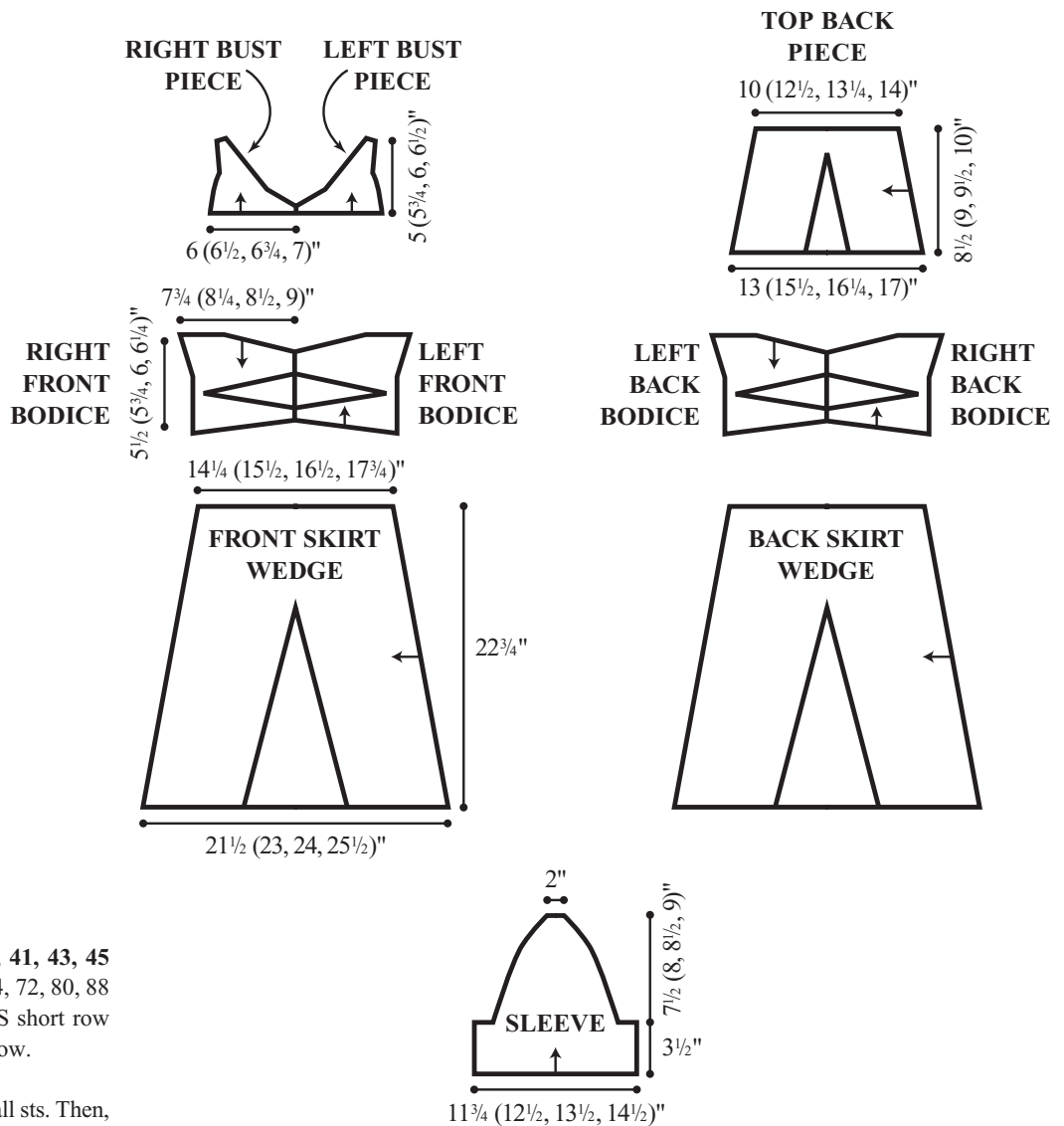

19 MODULAR STRIPE DRESS (CONTINUED)

Shown in *VK* Fall 2008 on page 94. Instruction on pages 134 & 135.

more, AT SAME TIME, dec 1 st at end of WS row every 4th row 4 times more—34 (36, 38, 40) sts.

Rows 20–22 Work even.

Short row shaping

Short row 23 (WS) K30, w & t.

Short row 24 and all even short rows Purl to end.

Short row 25 K22, w & t.

Short row 27 K14, w & t.

Short row 29 K6, w & t.

Short row 31 K4, w & t. Beg next row with row 5 of stripe pat and work as foll:

Short row 33 K14, w & t.

Short row 35 K22, w & t.

Short row 37 K30, w & t.

Short row 38 Purl to end.

Work even in stripe pat across all sts for 14 (16, 18, 20) rows.

Next row (WS) Bind off 7 (7, 8, 8) sts, k to end. Purl 1 row. Rep the last 2 rows 3 times more—6 (8, 6, 8) sts, end with row 1 (3, 5, 7). Bind off with A (A, B, A).

LEFT FRONT/ RIGHT BACK BODICE

Note These pieces are worked up from the waist edge to the top edge of the bodice and are mirror images of the RIGHT FRONT/ LEFT BACK BODICE.

(make 2 identical pieces)

With larger needles and A (A, B, A) cast on 6 (8, 6, 8) sts. Beg with row 1 (3, 5, 7) of 8-row stripe pat, work as follows:

Row 1 (WS) Knit.

Row 2 Purl.

Rows 3, 5, 7 and 9 Cast on 7 (7, 8, 8) sts, k to end.

Rows 4, 6 and 8 Purl—34 (36, 38, 40) sts. Cont in stripe pat for 14 (16, 18, 20) rows more.

Short row shaping

Work short rows 23–38 of right front/left back bodice at beg of WS rows. K 1 row, p 1 row.

Inc row (WS) K to last 2 sts, M1, k2.

Rep inc row every 4th row twice more. Work 2 rows even. Then, bind off 7 sts from center edge (beg of WS rows) 4 times, AT SAME TIME, rep inc row every 4th row twice more. Work 1 row even. Bind off rem 11 (13, 15, 17) sts.

TOP BACK PIECE

With larger needles and A, beg at right armhole edge, cast on 40 (42, 45, 47) sts. Beg with pat row 7 (5, 3, 1), work in rev St st stripe pat for 34 (36, 38, 40) rows, end with pat row 8. Cont in stripe pat as foll:

Short row shaping

Short row 1 (WS) K36, w & t.

Short row 2 and all even short rows Purl to end.

Short row 3 K28, w & t.

Short row 5 K20, w & t.

Short row 7 K12, w & t.

Short row 9 K6, w & t.

Short row 11 K4, w & t. Work next 2 rows with A.

Short row 13 K12, w & t. Beg next row with row 5 of 8-row stripe pat.

Short row 15 K20, w & t.

Short row 17 K28, w & t.

Short row 19 K36, w & t.

Short row 20 Purl to end.

Then cont in stripe pat on all sts until there are same number of stripes as first side. Bind off 40 (42, 45, 47) sts.

RIGHT BUST PIECE

Note This piece is worked with only A in rev St st. With larger needles and A cast on 28 (30, 32, 34) sts. Beg with a WS row, k 1 row, p 1 row, k 1 row.

Next row (RS) Bind off 2 sts (for neck edge), k to end. Cont to bind off from neck edge 2 sts 5 (5, 6, 6) times more, then dec 1 st 10 (12, 12, 14) times, AT SAME TIME, dec 1 st at armhole edge on the 5th row from beg, then every 8th row 3 times more—2 sts rem. Cut yarn and pull through these 2 sts to fasten off.